

APOLLO 280 SERIES

Outdoor Drinking Fountain with Bottle Filler

The Apollo 280 (A280) drinking fountain features a robust design with both bubbler and bottle refill outlets. With its custom-designed stainless-steel basin and feature front panel, sand/debris resistant activator button, WaterMark certification, and AS1428 compliance options, the A280 is practical, stylish and complements any contemporary urban streetscape or park setting.



KEY FEATURES

- Australian made
- 316 Stainless steel front panel, bubbler, basin and catchment tray (optional)
- Strong 8mm mild steel construction
- Easy water activation system
- Unique designed sand/debris resistant activator button
- Bottle refill outlet as standard
- Disabled accessible (complies with AS1428 with longer basin and reduced height options)
- Vandal resistant
- Easy installation fixings and easy access for maintenance
- Customisable with many options
- Powder coated in premium Dulux steel shield coating finish
- Full parts and technical back up service

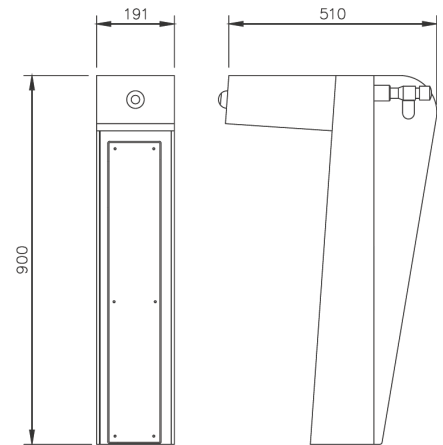

Technical Specifications

Total Height	900mm
Clearance Height	800mm
Base	191mm x 160mm



Model Selection

Model Selection	
AC-UFF-DFA280SSLBD	A280 Outdoor Fountain Stainless w/ Longer Basin + Tap & Dog Bowl
AC-UFF-DFA280SSLBC	A280 Outdoor Fountain Stainless w/ Longer Basin + Catchment Tray
AC-UFF-DFA280SSLB	A280 Outdoor Fountain Stainless w/ Longer Basin
AC-UFF-DFA280SSD	A280 Outdoor Fountain Stainless w/ Tap & Dog Bowl
AC-UFF-DFA280SSC	A280 Outdoor Fountain Stainless w/ Catchment Tray
AC-UFF-DFA280SS	A280 Outdoor Fountain Stainless Steel Standard (Bubbler + Bottle Refill)
AC-UFF-DFA280LBD	A280 Outdoor Fountain Powder Coated w/ Longer Basin + Tap & Dog Bowl
AC-UFF-DFA280LBC	A280 Outdoor Fountain Powder Coated w/ Longer Basin + Catchment Tray
AC-UFF-DFA280LB	A280 Outdoor Fountain Powder Coated w/ Longer Basin
AC-UFF-DFA280DB	A280 Outdoor Fountain Powder Coated w/ Tap & Dog Bowl
AC-UFF-DFA280C	A280 Outdoor Fountain Powder Coated w/ Catchment Tray
AC-UFF-DFA280	A280 Outdoor Fountain Powder Coated Standard (Bubbler + Bottle Refill)

Your Partner in Cool.

**AQUA
COOLER**

TECHNICAL SPECIFICATIONS

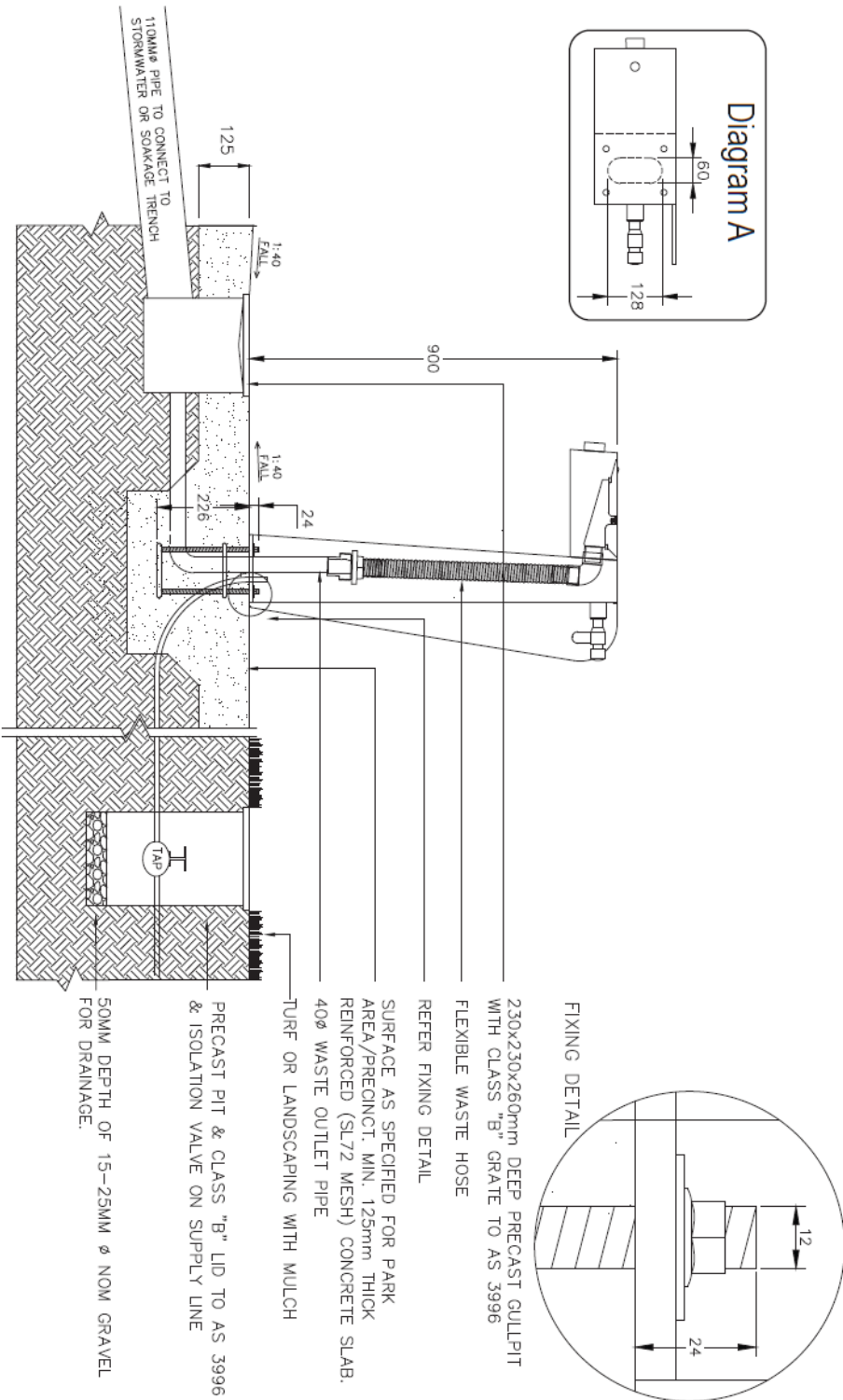

Your Partner in Cool.

**AQUA
COOLER**