



VERSAFILLER SERIES

Usage and Care Manual

Models: AC-PV8EBFY-ASM & AC-P8EBFTY-ASM

Your Partner in Cool.

AQUA
COOLER

PRODUCT DIAGRAM

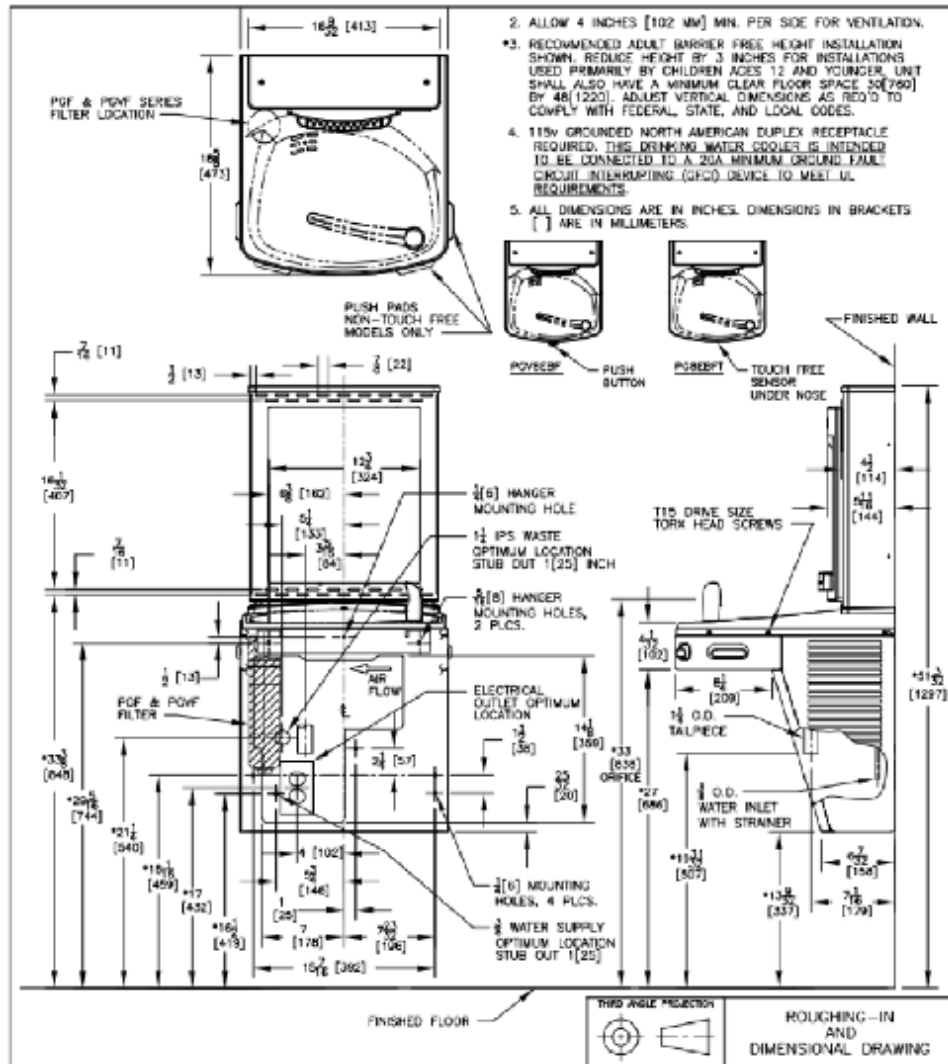

TECHNICAL SPECIFICATIONS

ITEMS:	SPECIFICATION:	
Refrigerant	Uses R134A refrigerant	
Water Connections	Water Inlet	DN15 BSP Male
	Water Outlet	<ul style="list-style-type: none"> Electronic (touch free) bottle filler Refrigerated vandal resistant Versacooler with bubbler
	Drain	DN40 metal banded metal flexible coupling
Thermostat Controls	The thermostat is factory set.	
Capacity	30L/h at 10°C water supply	
Power Consumption	340W	
Electrical	220-240V, 50/60 Hz	
Warranty	Twelve-month comprehensive coverage, additional twenty-four-month compressor replacement.	

IMPORTANT SAFETY INSTRUCTION

When using electrical appliances, basic safety precautions should be followed to reduce the risk of fire, electric shock and injury to persons or property. Read all instructions before using any appliance.

- Keep combustible material such as furniture, bedding, pillows, clothes and/or papers away from the unit.
- Do not operate this, or any other appliance, with a damaged power cable.
- No other appliance should be connected into the same power supply.
- Do not run the power cable over carpeting or other heat insulators.
- Keep the power cable away from high traffic areas.
- Do not submerge the power cable in water.
- We do not recommend the use of joint cables as they may overheat and increase the risk of fire.
- Exercise caution and use reasonable supervision when the appliance is used by or near children.
- Keep a minimum distance on each air-louvre side free.
- Do not use this product to dispense anything other than water.
- Do not use this product to dispense anything other than water.
- This appliance must be installed on an even and flat surface or wall.
- If the power cable or terminal is damaged, one of its service agents or a similarly qualified person must replace it to avoid hazard.
- Switch off the main power source before servicing the appliance.
- Warranty will be voided if installation is not carried out as detailed in this instruction manual.
- The compressor motor is equipped with an automatic reset protector which will disconnect the motor from the line in case of an overload.

IMPORTANT INFORMATION ABOUT GROUNDING

- To provide additional protection from the risk of shock, this unit must always be connected to a residual-current device (RCD) or a breaker. Use of joint cable should be avoided.
- This appliance must be grounded. Improper use of the grounding plug can result in a risk of electric shock, causing serious injury and possibly death.
- This appliance is equipped with the power terminal or power cord. A ground connection must be connected into a properly grounded, polarised outlet.
- Consult a qualified electrician if the grounding instructions are not completely understood, or if doubt exists as to whether the appliance is properly grounded.
- Do not under any circumstances cut or remove the third (ground) prong from the power cord plug (if provided). Do not use an adapter plug with this appliance.

INSPECTION

Inspect the cartons and various components for evidence of rough handling and concealed damage. Damage claims should be filed with the carrier.

INSTALLATION

The installation must be in accordance with AS/NZS 3500.1 and AS/NZS 3500.2, as well as the instructions below. Pipe jointing and installation is a trade skill and Aqua Cooler recommended this process is performed by qualified personnel only.

This drinking water cooler is designed to be operated at a water supply line pressure of up to 690kPa. The maximum operating temperature is 40°C. A pressure regulator must be installed in front of the unit's water inlet. (see End Connection section)

GETTING STARTED:

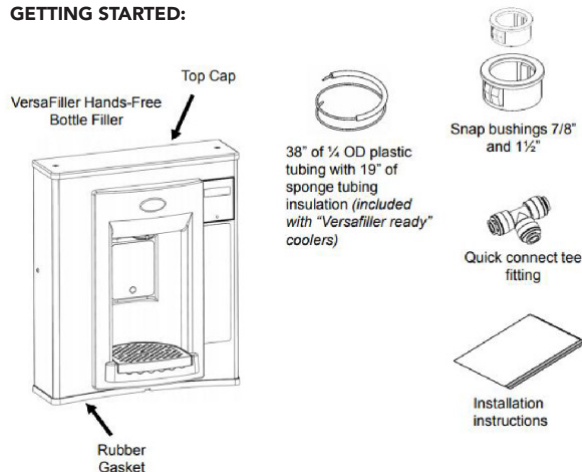

TOOLS REQUIRED:

- 3/8" pilot drill and either a step drill bit up to 7/8" diameter that will drill through SS top or 7/8" diameter punch die (retrofit version only)
- Electric drill; wrench for punch die
- 1/4" nut driver
- #2 Phillips screwdriver
- #15 torx bit driver
- Small tubing cutter for copper tube

INSTALLATION CONT.

ROUGH IN DRAWING

Plumbing rough-in and wall opening should be prepared as shown on Roughing-in drawing.

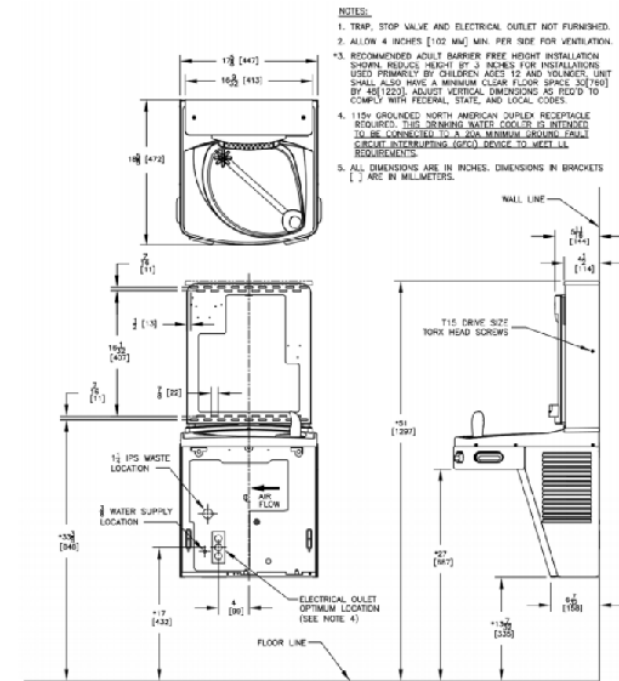

INSTALLATION A: Drilling hole in the top for water line connection

1. Disconnect power by unplugging unit. It might be necessary to remove the front panel to get access to the power.
2. Turn OFF water supply to the unit. It might be necessary to remove the front panel to access the water stop valve.
3. Place hole template onto cooler top so it is aligned with the left side of unit and wall.
4. Mark hole location.
5. Remove top from unit.

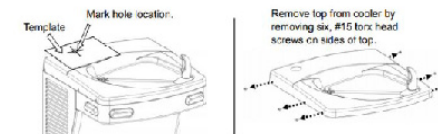

6. Using a step drill bit or 7/8" punch die, make a 7/8" hole through top. You may want to drill a pilot hole to get these started.
7. Install snap bushing into hole to protect tubing from being cut.

INSTALLATION CONT.

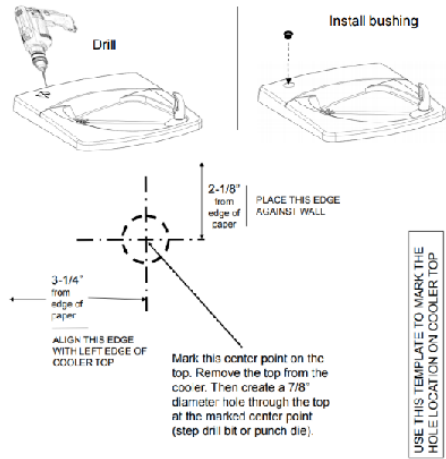

INSTALLATION B: Connecting the water line

For the single "Versafiller ready" cooler, the tube to connect to the Versafiller is found inside the access panel (the compressor compartment). This tube supplies cold water from the cooling tank to the Versafiller. For split level "Versafiller ready" coolers, the tube to plumb in the Versafiller is packaged in the dummy unit.

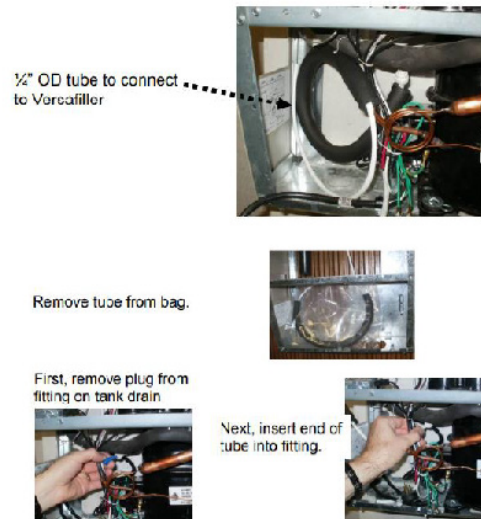

The tee and tube to the Versafiller are packaged with the PWEBF unit. One branch of the tee will supply the valve on the dummy unit, the other branch of the tee will connect to the Versafiller.

INSTALLATION CONT.

If a filter is being installed, cut a piece of tubing about 3" long to insert (optional) flow switch right after filter and before tee. This allows Versafiller counter to accurately calculate amount of water passing through filter.

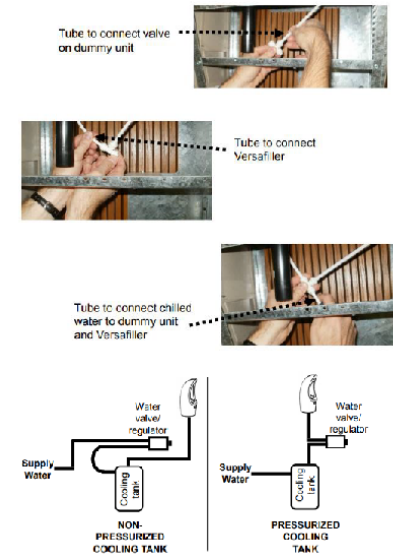

With the cooler top removed, find the tube going from the cooling tank outlet to the valve. The TEE fitting (supplied) will need to connect between the cooling tank and valve.

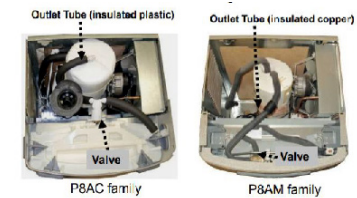

Disconnect tubing from the elbow on the valve.



INSTALLATION CONT.

Using the 38" piece of tubing provided, cut 6" and install it on the end of the TEE. Install the remaining tubing onto the branch of the TEE. Connect the other end of the TEE to the tank outlet tubing (tube that was disconnected from the elbow).

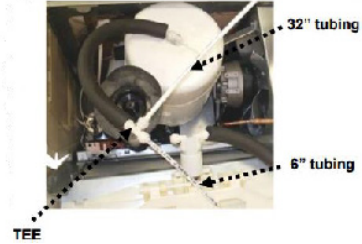

Route the TEE and tubing under the waste drain and connect the 6" length to the water valve elbow.



Feed black and blue tubing up through bushing in top. For single unit, also feed white tube attached to tee through bushing. Attach top to cooler. If flow switch was installed, cord from flow switch must also pass through this bushing.

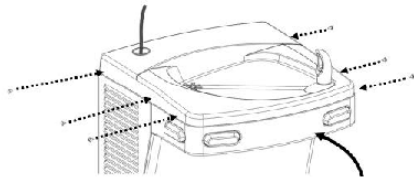

INSTALLATION C: Mounting the frame to the wall.

Place rubber gasket on top of the cooler so it is centred left/right and against the wall.

Set the wall frame onto the gasket. Centre it left/right and push it against the wall and mark hole locations for wall fasteners. The gasket will set the frame at the proper height.

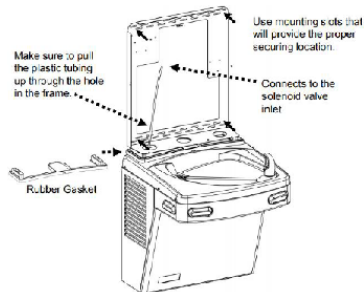

Secure frame to the wall with fasteners (not provided). Pull plastic tubing up through the hole in the frame.

INSTALLATION CONT.

Slide sponge tubing insulation over water line. Connect the tubing to the INLET of the solenoid on the back of the Hands-free VersaFiller assembly and (optional) flow switch connector into port on circuit board.

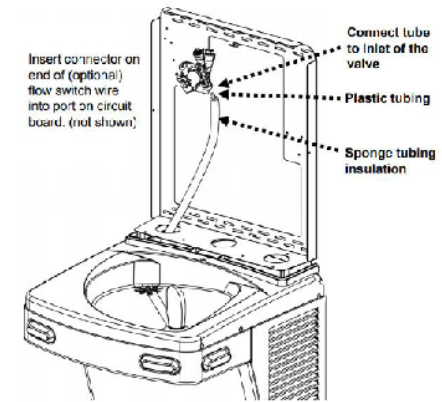

Install bottle filler tether with the steps below.

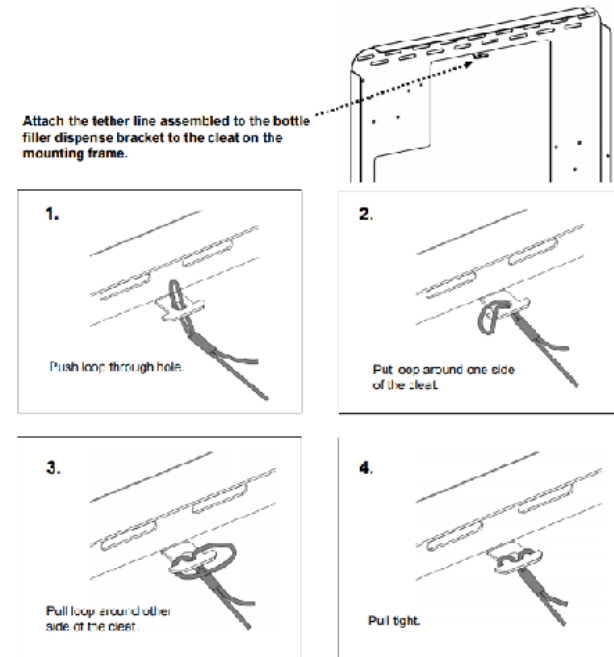

The tether keeps the bottle filler secured to the frame when changing the filter, if installed. Make sure the tether is installed properly to avoid accidental damage to the unit.

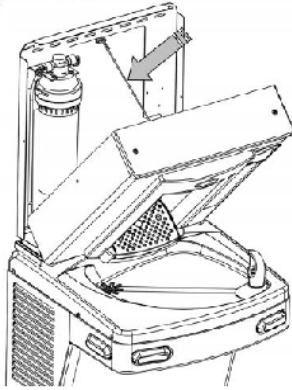

Before the Bottle Filler cabinet is set into place, feed the terminals on the power supply power cord and the long green ground wire through the bushing on the cooler top. Connect male terminals on the bottle filler power supply to female terminals on power cord. Make sure that the power cord is firmly connected to the power supply. Attach the long green ground wire to cooler power cord ground located on cooler frame or to electrical box ground. Make sure the cabinet fits into the groove in the rubber gasket on both sides and front of the wrapper.

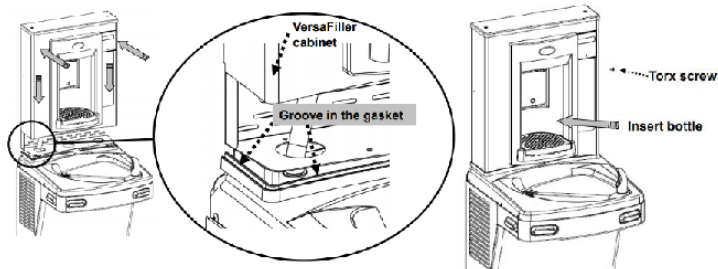

Attach Bottle Filler assembly to the frame using two (2) torx screws. If you are going to change the electronics default settings, remove the Top Cap and two (2) torx screws. Plug bottle filler cord into the electrical outlet. The program should be set up specific for that installation. See the program guide on next page. Access programming Pushbutton through top of Bottle Filler. Turn ON water supply and check for leaks. Place a container in the alcove to release any trapped air from the system. Plug in the power cord and replace the front panel. If everything works correctly, place the Top Cap back on the Bottle Filler and the two (2) torx screws to fasten it in place. Otherwise, calibrate the sensor per the instructions on the next page.

END CONNECTION:

The unit must be installed with the backflow prevention device complying with AS/NZS2845.1. The inlet end connection is DN15 BSP Male. Please refer to drawing below for instruction.

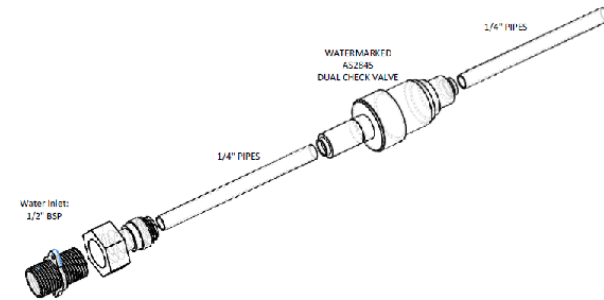

DRAIN CONNECTION:

Drain fitting must comply with AS1589 and AS2887. Aqua Cooler recommends this installation is performed by qualified personnel only. The parts for drain connection includes DN32 tee poly barb, 32mm marine flex hose, 30-45 stainless steel hose clamp and DN32xDN40 rubber coupling.

The drain connection is DN40 metal banded metal flexible couplings. Please refer to steps below for instruction.

NOTE: PV8EBFY only have one water fountain so please modify the drain connections accordingly. (Hose 3 is not needed)

1. Inspect image of installation assembly and cut hose to the following lengths: Hose 1: 700mm, Hose 2: 800mm, Hose 3: 400mm and Hose 4: 100mm
2. Prepare hot water (>80°C) and put the hose ends into the hot water for >30 seconds until soft before inserting them on the hose barbs to a depth of 30mm
3. Once the hose has been put onto the hose barb and the drainage pipes on the drinking fountains, tighten the hose clamps.
4. Connect the Rubber Coupling to the final hose barb tee outlet and check for leaks by plugging the DN40 outlet of the Rubber Coupling.

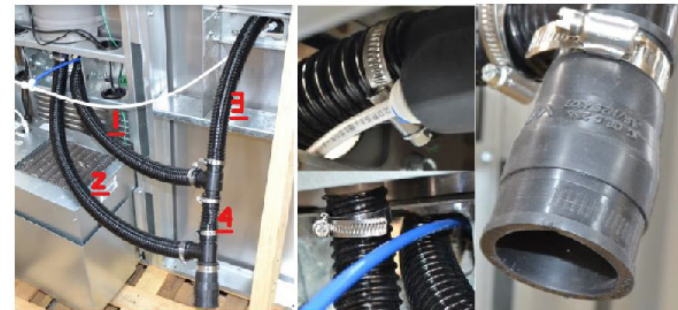

SET-UP GUIDES CONT.

BOTTLE FILLER ELECTRONICS:

Please review the installation section first. Before installing upper panel assembly with electronic bottle filler: change units from gallons (default setting) to litres. To ease access to the remote toggle button for programming once the panel assembly and fountain is installed, feed the remote toggle button through the fountain mounting plate.

Factory default program settings:

- Units: Gallons
- Unfiltered unit
- Flow meter = Rate selected
- Filter capacity = 1250 gallons (4731L) for VersaFilter
- Bottle count = 0.5L (1 bottle)
- Flow rate = 1.2 GPM
- 20s max dispense time.

To change the program settings, follow these steps:

DISPLAY	ACTION
000000000 BOTTLES REUSED (Home Screen)	Depress button for 3 seconds to enter into the following menu settings and make changes. Note: at anytime it will exit menu and save settings when idle for 10 seconds (no button press) and revert back to Home Screen.
LTR/GAL GAL	Depress button for 3 seconds to change from Gallons to Litres, or momentary press to advance to next menu.
UNFILTR/FILT? UNFILTR UNIT	Depress button for 3 seconds to change from Unfiltered to Filtered unit, or momentary press to advance to next menu
FLOW METER? RATE SELECTED	Depress button for 3 seconds to change from Rate Selected to (Flow) Meter Enabled, or momentary press to advance to next menu
SELECT RATE 1.2 GPM UNIT	To change flow rate, momentarily depress button to change whole gallon digit. Hold button 3 seconds to advance to TENTHS of gallon digit. Depress momentarily to change the digit. Hold button 3 seconds to advance to the next menu.
RESET 000000000 GALLON CNT [LTR COUNT]	Depress button for 3 seconds to reset Gallon or Litre count, or momentary press to advance to next menu
FILT CAPAC OF 1250 GAL [4731 LTR]	Depress button for 3 seconds to change filter capacity to 3000 GAL [11355 Litres] for Versafiller I or Galaxi green filter, or momentary press to advance to next menu
3 sec rule? 0.5L	Depress button for 3 seconds to switch from 0.5L bottle to 3 sec rule, or momentary press to advance to next menu. (The 3 Sec rule increases the bottle count based on a 3 second dispense.)
RESET 00000000 BOT COUNT?	Depress button for 3 seconds to reset (Home Screen) BOTTLES REUSED count, or momentary press to advance to next menu.
Bot Filler Set_time:20s	Depress button for 3 seconds to change maximum dispense time to 10, 20, or 30 seconds, or momentary press advance to next menu.
RUN CAL AGAIN?	Depress button for 3 seconds to run calibration again, or momentary press to advance to next menu.

REMOVING FROM SERVICE

- Disconnect the power supply.
- Disconnect the water supply.
- Drain cooler by removing grille, closing supply valve, and draining water.
- Remove the drain plug and bubbler.

MAINTENANCE

The only maintenance required is the removal of dirt and lint from the condenser. Inspection should be made at 3 month intervals. Remove the grille and clean the condenser with a vacuum attachment.

This unit is equipped with a hermetically sealed compressor. No additional lubrication is required. The fan motor installed on this unit seldom needs oiling. If required, a few drops of SAE 10 oil should be used.

Aqua Cooler recommends the unit to be checked every month, ensuring there is no blockage in the condenser or in the back of the unit. Please remove all potentially harmful factors to prevent any scratch or damage to the unit.

If customers require the unit's spare parts information, please contact the Aqua Cooler service department for further assistance. The direct line is located on the back of this manual.

Recommended 6 monthly service

Full Inspection of unit

- Functionality of bubblers, bottle fillers drip trays, and refrigeration units checked
- Full inspection of hoses and internal fittings
- Check and adjust filter housing (if applicable)
- Adjustment of thermostat if required and operational testing performed
- Tank pressure relief valve inspected and adjusted where required.
- Incoming pressure limiting valve inspected and changed where required
- Units PCB settings checked and adjusted as required (on electronic models)

Thorough clean and sanitise unit

- Full internal and external clean of the unit performed with drink-safe cleaner
- Sell-filling systems and reservoirs are emptied and sanitised to maintain impeccable hygiene standards
- Ensured cleanliness of drip tray, outlets and exterior of unit.

Replacement of filter cartridges (filters sold separately)

- Filters are flushed and water is run through the taps to expel any carbon fines and air pockets

MARKS

The appliance complies with applicable ACMA regulatory arrangements (Regulatory Compliance Mark) and WaterMark WMTS 105:2016.



TROUBLESHOOTING

PROBLEM	POSSIBLE CAUSE	REMEDY
Controller is faulty	Temperature sensor is faulty	Check sensor connections.
	Controller display is faulty	Contact Aqua Cooler service team.
No water flowing out of the unit	Water source has been suspended	Restore water supply
	The system is clogged	Check the pipes
	Solenoid valve is faulty	Check controller and cable connections
Unit does not dispense cold water	The cooling controller is turned off	Check the position of the mechanical thermostat and set to desired temperature
	Power failure	Check the power cord is properly plugged in or if there is a power outage
	The ventilation around the unit is insufficient	Ensure sufficient ventilation space around the unit
	System malfunction	Contact Aqua Cooler service team.
	The temperature of the incoming water is too high	Ensure the unit is not placed in direct sunlight or close to other heat sources
Unit is noisy during operation	Chiller unit in the machine is not level	Place the chiller unit on a level flat surface.
	Chiller unit is touching other objects	Ensure the chiller is standing free of any surrounding objects.
The water being dispensed has a strange taste.	This is not uncommon with new water coolers. Do not worry, this is not dangerous to your health.	Flush as per installation instructions. Perform cleaning procedure.

SPARE PARTS

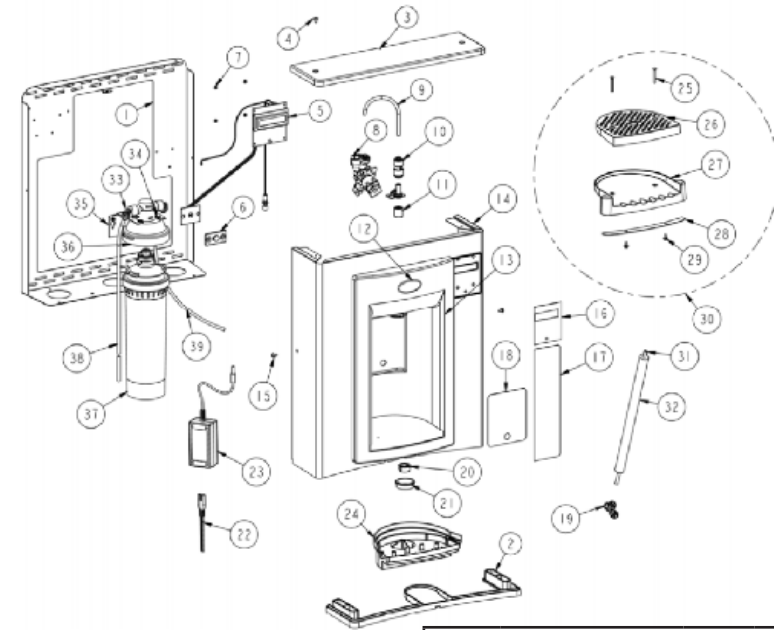

Electronic (Touch Free) Bottle Filler (Th filter section is not applicable for M8CREBFY)			
1	Frame	21	Snap Bushing
2	Gasket	22	Cord Assy, DC Power Supply
3	Cap	23	Power Supply, 100-240vac/12vdc
4	Screw	24	Drain
5	Electronics Assy	25	Screw
6	Lens, Bottle Filler	26	Tray
7	Nut	27	Tray
8	Solenoid Valve 2VDC	28	Drip Tray Bottom
9	Tube	29	Screw
10	Connection	30	Drip Tray Assembly
11	Flow Nozzle	31	Tube
12	Nameplate	32	Insulation
13	Alcove	33	Connection
14	Wrapper	34	Screw
15	Screw	35	Bracket
16	Label, LCD	36	Filter Head
17	Label, Panel	37	Filter Cartridge
18	Label, Sensor	38	Tube
19	Connection	39	Tube
20	Snap Bushing		

SPARE PARTS

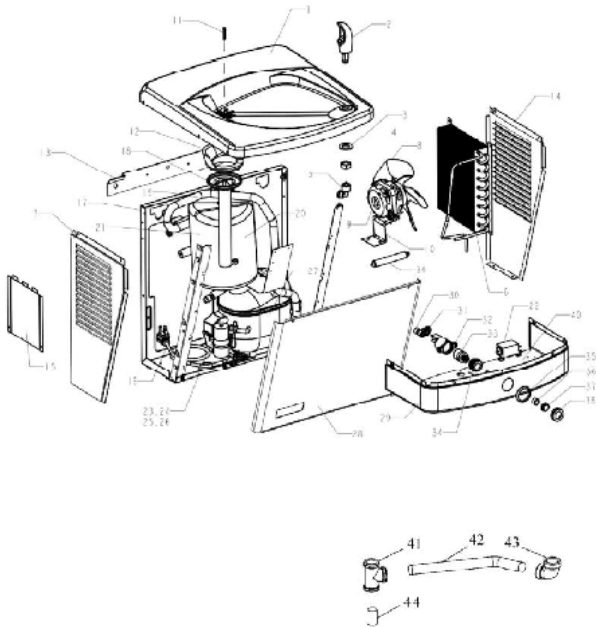

Split Level Drinking Fountain with Bubbler					
1	Top Frame	16	Service Cord	31	Elbow
2	Bubbler	17	Frame	32	Cartridge Holder
3	Washer	18	Waste Assy	33	Cartridge
4	Locknut	19	Insulation	34	Retaining Nut
5	Bubbler Nut	20	Insulation	35	Nut Ring
6	Condenser	21	Cooling Tank	36	Washer
7	Side Panel	22	Cold Control	37	Push Button
8	Fan Blade	23	Relay	38	Nut
9	Fan Motor	24	Overload	39	Drier
10	Fan Bracket	25	Start Capacitor	40	Shelf
11	Drain Screw	26	Run Capacitor	41	Waste Tee
12	Waste Gasket	27	Compressor	42	Waste Arm Assy
13	Hanger Bracket	28	Front Panel	43	Waste Elbow
14	Side Panel	29	Front Nosepiece	45	Waste Extension Tube
15	Patch Plate	30	Union		

WARRANTY & SERVICE REGISTRATION

For All Aqua Cooler Water Cooler and Fountain Products

Effective July 2017

Aqua Cooler Pty Ltd warrants this appliance to the first purchaser as follows and subject to the stated conditions.

12 Month Comprehensive Warranty - Any defect in the appliance occurring within the first twelve months from the date of purchase will be rectified free of charge by Aqua Cooler Pty Ltd or by any authorised independent Service Agent.

24 Month Extended Warranty - Aqua Cooler Pty Ltd agrees to replace any part of the hermetically sealed refrigeration system which becomes inoperative in the two years following the first years comprehensive warranty. This extended warranty covers the compressor, condenser, and interconnecting refrigeration pipework. It excludes compressor relays, overloads and all other components of this appliance. This extended warranty does not include service, repair or labour costs or any pickup and/or freight charges. Aqua Cooler at its sole discretion may replace the cooler with a new or refurbished cooler of a similar age.

Warranty Exclusions

1. Any costs associated with the removal and reinstallation of repaired or replaced units.
2. Travel expenses to locations further than 100km from any Australian Capital City CBD or further than 100km of a registered Service Agent.
3. Damage to units where mains connected pressure is higher than 700kPa and a pressure limiting valve is not installed.
4. Where the unit is not installed as per installation instructions found within the supplied user manual.
5. The warranty does not cover defects occasioned by misuse, alterations, accident or where the water cooler has been stored on its side.

**FOR ANY CLAIMS UNDER THIS WARRANTY PLEASE CONTACT AQUA COOLER PTY LTD
PHONE: +61 (02) 9721 9300 OR EMAIL: support@aquacooler.com.au**

Thank you for your custom and we hope our product provides many years of fault free operation. To enable us to register your warranty and provide the best possible service should a problem occur, we recommend you fill out the section below and return it to us immediately.

This warranty is provided in addition to other rights and remedies you have under law: Our goods come with guarantees which cannot be excluded under the Australian Consumer Law. You are entitled to replacement or refund for a major failure and to compensation for other reasonably foreseeable loss or damage. You are also entitled to have the good repaired or replaced if the goods fail to be of acceptable quality and the failure does not amount to a major failure.

Warranty & Service Registration Form

Please fill in this form and mail to us or send via email to support@aquacooler.com.au. If this form is not completed and returned the warranty period will be deemed to have commenced from date of manufacture.

COMPANY NAME (if applicable):

CONTACT NAME: PHONE NUMBER:

ADDRESS:

SUBURB: POSTCODE:

MODEL NUMBER: SERIAL NUMBER:

PURCHASED FROM:

DATE OF PURCHASE:



AQUA
COOLER

Your Partner in Cool.

Phone Numbers

Sales: 1300 278 226
Service: 1800 278 226

Address

U14, 2-12 Knobel Court
Shailer Park QLD 4128

Internet

www.aquacooler.com.au
info@aquacooler.com.au