



MP-XL SERIES

Usage and Care
Manual

Your Partner in Cool.

AQUA
COOLER

PRODUCT DIAGRAM

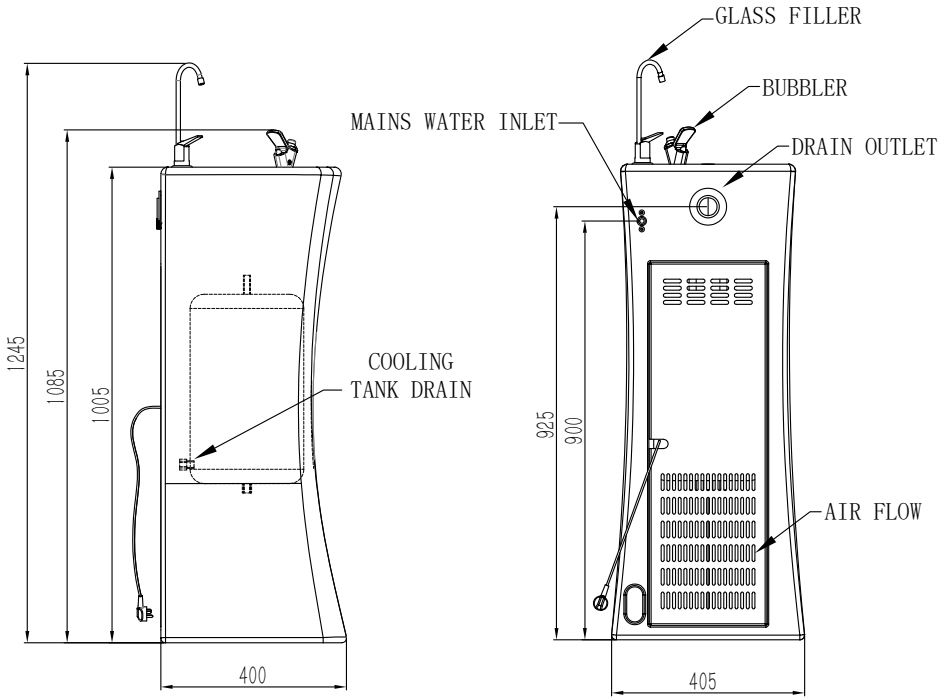

TECHNICAL SPECIFICATIONS

Water Reservoir	10 L	
Refrigeration	Uses R134A refrigerant	
Water Connections	Water Inlet	½" Male B.S.P
	Drain Outlet	40 mm Female P.V.C Socket
Thermostat Control	The thermostat is factory set.	
Capacity	30 L/h	
Power Consumption	216 W	
Electrical	220-240 V, 50/60 Hz	
Warranty	Twelve month comprehensive coverage, additional twenty-four month compressor replacement.	

IMPORTANT SAFETY INSTRUCTIONS

When using electrical appliances, basic safety precautions should be followed to reduce the risk of fire, electric shock and injury to persons or property. Read all instructions before using any appliance.

1. Keep combustible material such as furniture, bedding, pillows, clothes and/or papers away from the back of the unit.
2. Do not operate this, or any other appliance, with a damaged power cord.
3. No other appliance should be plugged into the same outlet. Be sure that the plug is fully inserted into the outlet.
4. Do not run the power cord over carpeting or other heat insulators.
5. Do not cover the power cord.
6. Keep the power cord away from high traffic areas.
7. Do not submerge the power cord in water.
8. We do not recommend the use of extension cords as they may overheat and increase the risk of fire.
9. Exercise caution and use reasonable supervision when the appliance is used by or near children.
10. Make sure that there is at least 75 mm of space between the back of unit and wall. Keep a minimum of 75 mm on each side of unit free.
11. Do not use this product to dispense anything other than water.
12. This appliance must be placed on an even and flat surface.
13. If the supply cord is damaged, the manufacturer, one of its service agents or a similarly qualified person must replace it in order to avoid hazard.
14. This water fountain must be positioned so the plug is accessible.
15. Disconnect the plug from the outlet when not in use.
16. Remove power plug or disconnect from main power source before servicing the appliance.
17. Warranty will be voided if installation is not carried out as detailed in this instruction manual.
18. The compressor motor is equipped with an automatic reset protector which will disconnect the motor from the line in case of an overload.

IMPORTANT INFORMATION ABOUT GROUNDING

- To provide additional protection from the risk of shock, this unit **MUST** be connected to a residual-current device (RCD) outlet at all times. Use of an extension cord will void any warranties.
- This appliance must be grounded. Improper use of the grounding plug can result in a risk of electric shock, causing serious injury and possibly death.
- This appliance is equipped with a power cord having a grounding wire with a grounding plug and must be connected into a properly-grounded, polarised outlet.
- Consult a qualified electrician if the grounding instructions are not completely understood, or if doubt exists as to whether the appliance is properly grounded. If the wall outlet is a standard, 2-prong outlet, it is your personal responsibility and obligation to have it replaced with a properly-grounded, 3-prong wall outlet.
- Do not under any circumstances cut or remove the third (ground) prong from the power cord plug. Do not use an adapter plug with this appliance.

UNPACKING THE WATER FOUNTAIN

1. After unpacking the water fountain, wipe with a soft cloth. Check the unit for evidence of rough handling.
2. Place the machine on a hard, flat surface. Make certain the unit is level. The unit should not be close to sources of heat, otherwise performance may be affected.
3. It is best to place the water fountain in an area with good air circulation. Make sure there is at least 75 mm of space between the back of the fountain and the wall.

INSTALLATION

The installation must be in accordance with AS/NZS 3500.1 and AS/NZS 3500.2. Pipe jointing is a trade skill and Aqua Cooler recommends this process is performed by qualified personnel only.

1. Ensure proper ventilation by allowing 75 mm clearance on each side of the fountain.
2. Minimum water pressure is 100 kPa and maximum is 700 kPa.
3. The recommended maximum water inlet temperature is 38°C.
4. Install a 40 mm waste trap onto the waste outlet on the rear of the fountain - not supplied.
5. Water in connection is secured via a ½" kinko nut and olive into the stainless-steel connection on the rear of the unit. It is recommended that a ½" shut off valve is installed at this point for ease of future maintenance.
6. Turn on water supply and hold down bubbler to purge the system of air until a steady stream of water comes from the tap.
7. For models equipped with a glass filler, please remove the white tubing from the hole and then assemble the glass filler by placing the neck into the hole on the top of the lid, as shown below.
8. The bubbler needs to be adjusted for the correct water flow in relation to the local water pressure. On the side of the bubbler is an inner and an outer screw. Once you have established water flow, adjust the inner screw until the stream is in the center of the stainless-steel top.
9. Check all connections for water leaks.
10. Flush fresh mains water through the unit for five minutes to ensure any residual water from testing is cleared.
11. Plug the fountain into the building electrical supply. The unit will start automatically.

DRAIN INSTALLATION

NOTE: Pipe jointing is a trade skill and should be executed only by qualified persons. Aqua Cooler recommends installing a union as part of the PVC drain assembly to enable ease of disconnection if the fountain requires service.

1. Make sure all connections are cleaned and dry.*
2. Mark waste pipe at a distance equivalent to full depth once inserted into the drain fitting on the unit.
3. Apply Watermark certificated Type N solvent cement on the end of the Watermarked AS/NZS 1260 40mm PVC pipe and insert into the Aqua Cooler drain outlet fitting. Firstly to the inside of the M Series drain fitting and then to the external surface of the pipe end (marked area). (See Figure.1) #
4. Please ensure the solvent cement is applied in full even coats to all applicable surfaces.
5. Follow the direction line in figure.1 to connect the PVC pipe to the full depth of the socket and hold the bond joint in position for at least 30 seconds.
6. Do not disturb for 5 minutes and allow 24 hours curing before testing. (See Figure.2)

* Aqua Cooler suggests using PVC priming fluid to prime PVC pipe prior to application of PCB pipe cement for all installations.

#2: Using both pipe cement type N and type P are both acceptable. Pipe cement type P is recommended in high pressure application for bonding, while type N is for the non-pressure application. Aqua Cooler recommends using pipe cement type N complying with AS/NZS3879 for this application.

Please be aware that the connection should be done by an Australian certified plumber.

The socket is adaptable to Watermarked AS/NZS 1260 40mm PVC pipe fitting as per the WMTS105 documentation.

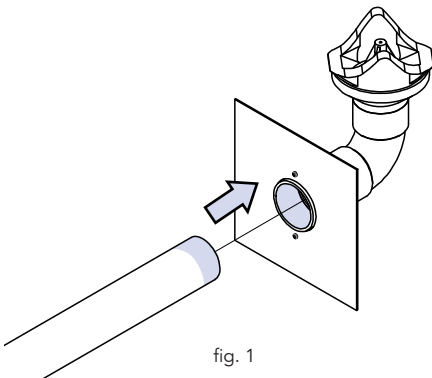

fig. 1

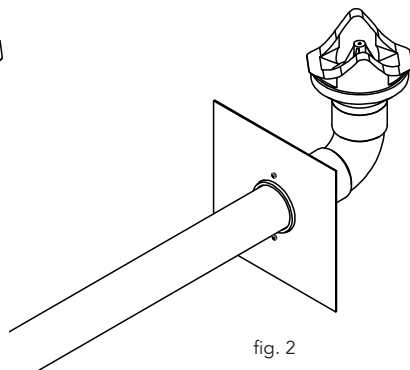

fig. 2

REMOVING FROM SERVICE

1. Disconnect the power supply cord.
2. Disconnect the water supply.
3. Remove drain assembly from rear of the fountain.
4. Remove bubbler valve and if present, glass filler.
5. Always drain all water when freezing temperatures are anticipated and before shipping the fountain.

MAINTENANCE

- The only maintenance operation required is the removal of dirt and lint from the condenser. Inspection should be made at 6 month intervals.
 1. Disconnect the power supply.
 2. Clean the condenser with a small stiff non-wire brush.
- The unit is equipped with a hermetically sealed compressor and requires no additional lubrication.
- The fan motor on this unit seldom needs oiling. If required, a few drops of SAE 10 oil should be used.
- Aqua Cooler recommends the water fountain is cleaned every month, ensuring there is no blockage in the condenser or in the back of the unit. Please remove all potentially harmful factors to prevent any scratch or damage to the unit.
- If customers require the unit's spare parts information, please contact the Aqua Cooler Service Department for further assistance. The direct line is located on the back of this manual.

Recommended 6 monthly service

Full Inspection of unit

- Functionality of bubblers, glass fillers drip trays, and refrigeration units checked
- Full inspection of hoses and internal fittings
- Check and adjust filter housing (if applicable)
- Adjustment of thermostat if required and operational testing performed
- Tank pressure relief valve inspected and adjusted where required.
- Incoming pressure limiting valve inspected and changed where required

Thorough clean and sanitise unit

- Full internal and external clean of the unit performed with drink-safe cleaner
- Sell-filling systems and reservoirs are emptied and sanitised to maintain impeccable hygiene standards
- Ensured cleanliness of drip tray, outlets and exterior of unit.

Replacement of filter cartridges (filters sold separately)

- Filters are flushed and water is run through the taps to expel any carbon fines and air pockets
- Taste test and visual inspection is conducted to ensure units provide the highest quality drinking water

TROUBLESHOOTING

Problem	Possible Cause	Remedy
No water flowing out of the glass filler or bubbler	Water source has been suspended	Restore water supply.
	The filtration system is clogged	Replace the filter.
Water is not cold	The cooling controller is turned off	Check the position of the mechanical thermostat and set to desired temperature.
	Power failure	Check the power cord is properly plugged in or if there is a power outage.
	Cooling system failure	Turn off the fountain and contact Aqua Cooler service.
Water is continually flowing internally from tank through to drain	Internal Pressure Release Valve (PRV) is not set correctly to suit customers premise	Use flat blade screw driver to adjust pressure release valve very gently clockwise until water stops dripping. This is an overpressure safety system to prevent the tank bursting. Ensure that adjustments are made to the PRV carefully. Be sure that the cause of the dripping is not that actually the tank is frozen solid caused by faulty thermostat or very low ambient temperature conditions.
Low flow through bubbler outlet	Bubbler valve screw not adjusted according to water pressure	Adjust small screw on side of bubbler gently while activating the bubbler valve using the foot sensor so flow is increased/decreased based on your needs.
	Units Pressure Limiting Valve (PLV) is faulty	Bypass the units grey cylinder shaped pressure limiting valve on the internal pipe work between rear inlet connection and tank. If the flow is correct after bypass, please contact Reece for support.
Low flow through glass filter unit	Units Pressure Limiting Valve (PLV) is faulty	Bypass the units grey cylinder shaped pressure limiting valve on the internal pipework between rear inlet connection and tank. If the flow is ok after bypass, please contact Aqua Cooler for support.

EXPLODED DIAGRAM

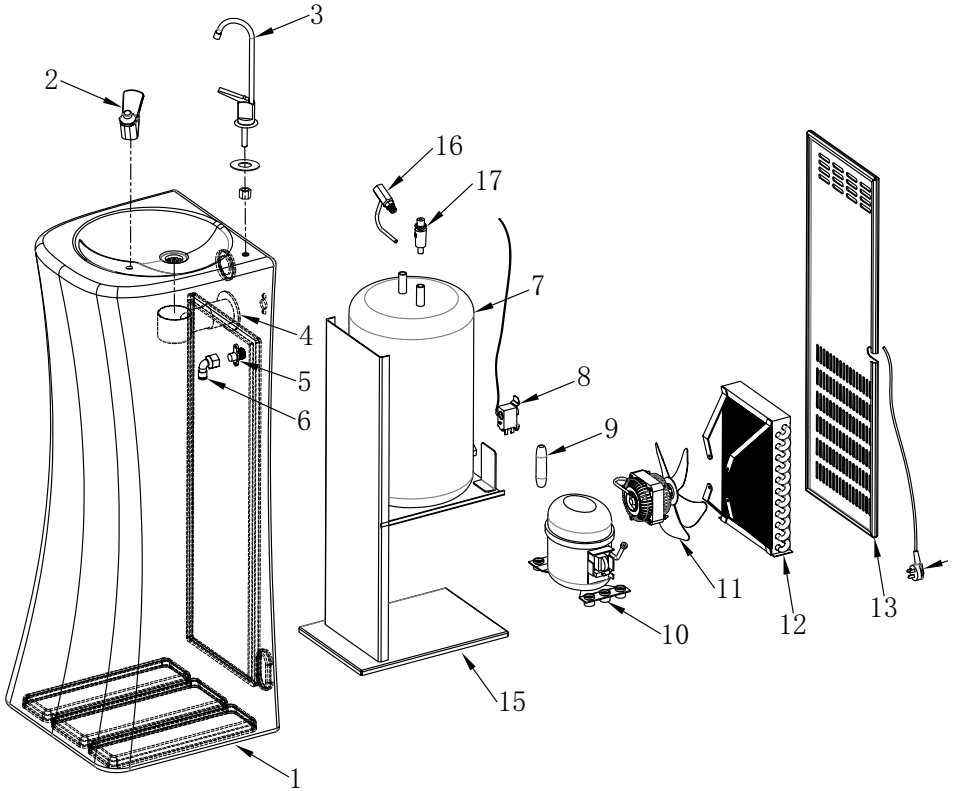

SPARE PART LIST

#	Description	Code
1	Frame	SPM1
2	Bubbler Valve	SPM2
3	Glass Filler	SPM3
4	Waste Drain Elbow	SPM4
5	1/2 SST Inlet Connector	SPM5
6	1/2 To 1/4 Connector	SPM6
7	Cold Tank Assembly	SPM7
8	Cold Thermostat	SPM8
9	Desiccant	SPM9
10	Compressor	SPM10

#	Description	Code
11	Fan Motor	SPM11
12	Condenser	SPM12
13	Real Panel	SPM13
14	Power Cord	SPM14
15	Fixed Bracket	SPM15
16	Decompression	SPM16
17	Pressure Reducing Valve	SPM17

ELECTRICAL DIAGRAM

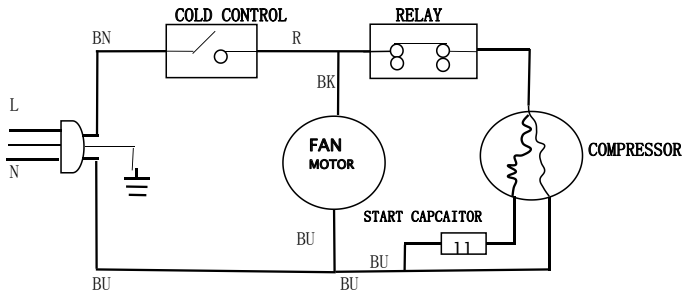

MARKS



WaterMark

Spec No. WMTS 105:2016
SAI GLOBAL
WMK26317 (Lic. No.)

The appliance is comply with applicable ACMA regulatory arrangements (Regulatory Compliance Mark) and WaterMark WMTS 105:2016.

WARRANTY AND SERVICE REGISTRATION

For All Aqua Cooler Water Cooler and Fountain Products

Effective July 2017

Aqua Cooler Pty Ltd warrants this appliance to the first purchaser as follows and subject to the stated conditions.

12 Month Comprehensive Warranty - Any defect in the appliance occurring within the first twelve months from the date of purchase will be rectified free of charge by Aqua Cooler Pty Ltd or by any authorised independent Service Agent.

24 Month Extended Warranty - Aqua Cooler Pty Ltd agrees to replace any part of the hermetically sealed refrigeration system which becomes inoperative in the two years following the first years comprehensive warranty. This extended warranty covers the compressor, condenser, and interconnecting refrigeration pipework. It excludes compressor relays, overloads and all other components of this appliance. This extended warranty does not include service, repair or labour costs or any pickup and/or freight charges. Aqua Cooler at its sole discretion may replace the cooler with a new or refurbished cooler of a similar age.

Warranty Exclusions

1. Any costs associated with the removal and reinstallation of repaired or replaced units.
2. Travel expenses to locations further than 100km from any Australian capital city CBD or further than 100km of a registered Service Agent.
3. Damage to units where mains connected pressure is higher than 700 kPa and a pressure limiting valve is not installed.
4. Where the unit is not installed as per installation instructions found within the supplied user manual.
5. The warranty does not cover defects occasioned by misuse, alterations, accident or where the water cooler has been stored on its side.

FOR ANY CLAIM UNDER THIS WARRANTY PLEASE CONTACT AQUA COOLER PTY LTD

PHONE: +61 (02) 9721 9300 OR EMAIL: support@aquacooler.com

Thank you for your custom and we hope our product provides many years of fault free operation. To enable us to register your warranty and provide best possible service should a problem occur, we recommend you fill out the section below and return it to us immediately.

This warranty is provided in addition to other rights and remedies you have under law: Our goods come with guarantees which cannot be excluded under the Australian Consumer Law. You are entitled to replacement or refund for a major failure and to compensation for other reasonably foreseeable loss or damage. You are also entitled to have the goods repaired or replaced if the goods fail to be of acceptable quality and the failure does not amount to a major failure.

Warranty and Service Registration Form

Please fill in this form and mail to us or send via email to support@aquacooler.com If this form is not completed and returned the warranty period will be deemed to have commenced from date of manufacture.

COMPANY NAME (if applicable):

CONTACT NAME:

PHONE NUMBER:

ADDRESS:

SUBURB:

POSTCODE:

MODEL NUMBER:

SERIAL NUMBER:

PURCHASED FROM:

DATE OF PURCHASE:

Your Partner in Cool.



AQUA COOLER

Your Partner in Cool.

Phone Numbers

Sales: 1300 278 226

Service: 1800 278 226

Address

30-36 Relentless Court
Park Ridge Qld 4125 Australia

Internet

www.aquacooler.com.au
info@aquacooler.com

© Aqua Cooler 2026 - Version 1024

This document is available digitally on our website at www.aquacooler.com.au/drinking-fountain/mp-xl-series/