



VERSAFILLER SERIES

Usage and Care Manual

Models: AC-P8EBFSLTTY-ASM & AC-PV8EBFSLY-ASM

Your Partner in Cool.

AQUA
COOLER

IMPORTANT SAFETY INSTRUCTION

When using electrical appliances, basic safety precautions should be followed to reduce the risk of fire, electric shock and injury to persons or property. Read all instructions before using any appliance.

- Keep combustible material such as furniture, bedding, pillows, clothes and/or papers away from the unit.
- Do not operate this, or any other appliance, with a damaged power cable.
- No other appliance should be connected into the same power supply.
- Do not run the power cable over carpeting or other heat insulators.
- Keep the power cable away from high traffic areas.
- Do not submerge the power cable in water.
- We do not recommend the use of joint cables as they may overheat and increase the risk of fire.
- Exercise caution and use reasonable supervision when the appliance is used by or near children.
- Keep a minimum distance on each air-louvre side free.
- Do not use this product to dispense anything other than water.
- Do not use this product to dispense anything other than water.
- This appliance must be installed on an even and flat surface or wall.
- If the power cable or terminal is damaged, one of its service agents or a similarly qualified person must replace it to avoid hazard.
- Switch off the main power source before servicing the appliance.
- Warranty will be voided if installation is not carried out as detailed in this instruction manual.
- The compressor motor is equipped with an automatic reset protector which will disconnect the motor from the line in case of an overload.

IMPORTANT INFORMATION ABOUT GROUNDING

- To provide additional protection from the risk of shock, this unit must always be connected to a residual-current device (RCD) or a breaker. Use of joint cable should be avoided.
- This appliance must be grounded. Improper use of the grounding plug can result in a risk of electric shock, causing serious injury and possibly death.
- This appliance is equipped with the power terminal or power cord. A ground connection must be connected into a properly grounded, polarised outlet.
- Consult a qualified electrician if the grounding instructions are not completely understood, or if doubt exists as to whether the appliance is properly grounded.
- Do not under any circumstances cut or remove the third (ground) prong from the power cord plug (if provided). Do not use an adapter plug with this appliance.

INSPECTION

Inspect the cartons and various components for evidence of rough handling and concealed damage. Damage claims should be filed with the carrier.

INSTALLATION

The installation must be in accordance with AS/NZS 3500.1 and AS/NZS 3500.2, as well as the instructions below. Pipe jointing and installation is a trade skill and Aqua Cooler recommended this process is performed by qualified personnel only.

The water cooler contains the refrigeration system and is always mounted on the right side. This unit can be configured with the water cooler high or low. Refer to proper roughing in drawing for location of plumbing and electrical service. Filter units have additional instructions on a label inside fountain side access panel. Read these before installing unit. This drinking water cooler is designed to be operated at a water supply line pressure of up to 100 psi (690 kPa). A pressure regulator must be installed in front of the unit's water inlet if the water pressure (including any possible pressure spikes) could exceed 100 psi (690 kPa).

FLUSH BUILDING WATER SUPPLY BEFORE INSTALLING UNIT.

Install wall hangers as shown on the desired roughing in drawing. Wall hangers are shipped fastened to the backs of each unit.

To configure this cooler for right side high or right side low installation, refer to details below. Bottom screws of the appropriate side panel may be temporarily removed to install patch plate. Assemble drains as shown below, matching the position of the gaskets to the contour of the cooler tops.

Mount the water cooler on the right hanger.

Mount water fountain on left side hanger while routing "Water In" tube through access hole to stop valve as required. Remove cap from "Drain/Remote Cold Water" connection and insert "Water In" tube.

All provided waste drain parts for field installation are packed in the water fountain. Assemble drain per appropriate roughing in drawing. The short leg of the crossover piece will be on the water cooler side. When unit has an internal waste trap, it should be wrapped with insulating tape to prevent sweating. Use of 1-3/4" knockout for a waste line is not recommended because of potential conflict with ADA* toe space requirements. Check with your local building code inspector for approval.

Install a shut off valve in water supply line. An in-line strainer is furnished in "Water Supply" tube. Connect "Water Supply" tube to shut off valve. This connection should not be a solder joint or flare connection to allow access to the strainer service. To ease removal of the strainer, a sheet metal screw may be lightly threaded into the open end.

Rotate fan blade by hand to see that it is free of obstructions.

Check available power supply against water cooler data plate to assure correct electrical service. This drinking water cooler is intended to be connected to a 20A minimum ground fault circuit interrupting (GFCI) device to meet UL requirements. Plug power supply cord into wall outlet. The rear most 1-3/8 diameter knockout in frame bottom is for an externally located electrical supply. Make sure knockout hole edge is smooth and free of any burrs. Use of Heyco bushing #2184 in knocked out hole is recommended to prevent damage to service cord and to close up excess opening around cord. Route cord so it does not interfere with ADA* space requirements.

INSTALLATION CONT.

To fill cold water tank on water cooler, open water supply line shut-off and push any one of front push pads to allow water to flow to bubbler. On TM and TT models, actuate solenoid by holding one hand approximately 1" from infrared sensor (under front edge of shelf). Run water until stream is free of bubbles. After approximately 30 seconds run time, solenoid valve will automatically shut off. To reactivate, move hand away for an instant and then again place it in front of sensor.

To Adjust Bubbler stream:

All models are equipped with a cartridge regulator. The standard push pad and electric eye models have a slot at back of underside of shelf. Insert a screwdriver in this slot to adjust regulator. Turn adjustment clockwise to increase stream height. To access PGM8ACSL and PGMF8ACSL adjustment, remove the Bezel and Button from front of cooler.

To adjust beam range of sensor (TM and TT models only):

1. Shut off water. Actuate sensor to relieve water pressure. NOTE: Unplug cooler or avoid touching fan blade and electrically live components when adjusting sensor.
2. Remove six screws holding top on. Lift up front to access sensor.
3. To adjust sensing distance, use a mini-screwdriver (2.5mm flat tip or smaller) and rotate adjustment potentiometer screw on side of sensor. Turn clockwise to sense objects further away. This is represented by thicker end of curve on sensor label. The screw can be turned a maximum of $\frac{3}{4}$ turns. Sensor has a maximum range of approximately 14", it is factory set at 4".
4. NOTE: Do not turn adjustment as high as it can go. If you do, sensor will lock on until you turn sensing distance back down.
5. There is an adjustable on-time delay if desired. It is factory set for immediate response upon activation. To adjust on-time delay, rotate blue knob on timer clockwise. The maximum on-time delay is 1 second. Water will shut off immediately once object is removed from under shelf. Maximum on-time is 30 seconds should someone tamper with sensor. NOTE: Floors with a reflective finish, i.e., ceramic tile, may cause false actuation no matter what sensor adjustment is for distance. Therefore, do not install unit in such an area or dull surface of floor so it will not reflect light.
6. Replace top, starting at back of unit, snug up screws, but do not overtighten.

VERSAFILLER INTERNAL SETUP

1. Generic Model Internal Setup

1.1 Before internal adjustments/out of box

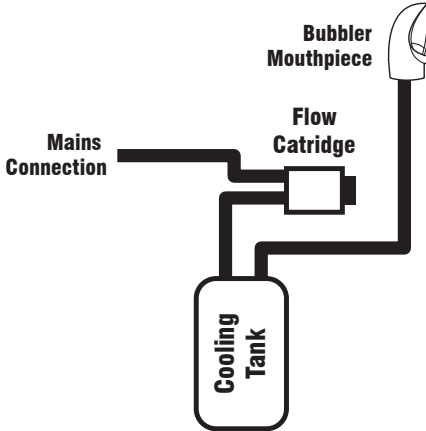

1.2 After rearranging internal water pipe

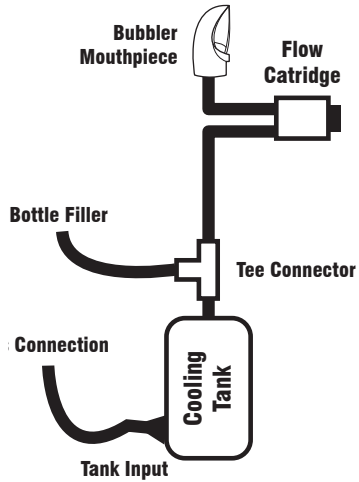

2.1 Before internal adjustments/out of box

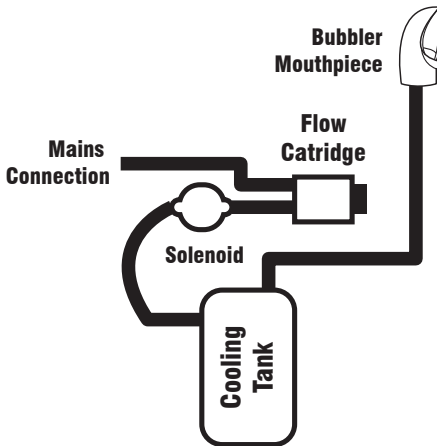

2.2 After rearranging internal water pipe

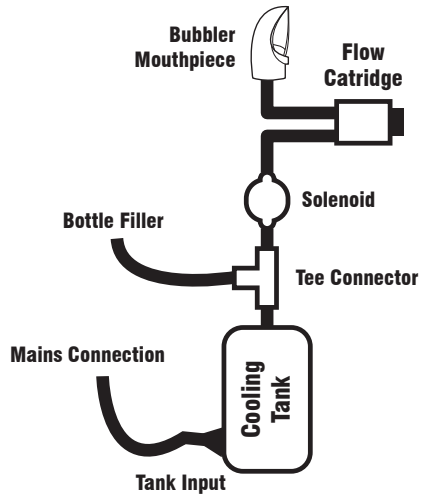

3. Generic Model Internal Setup

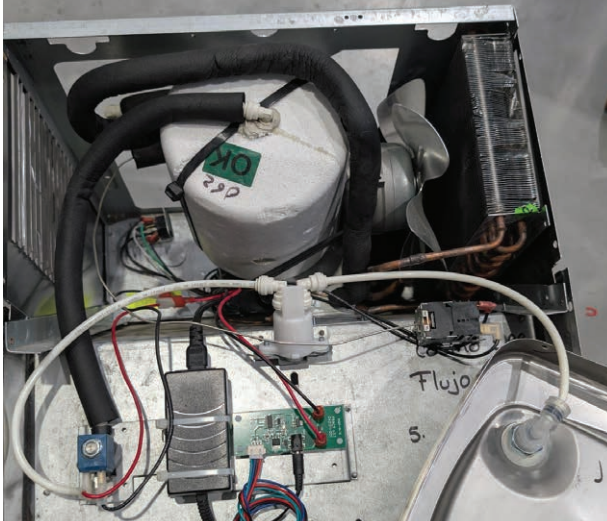

4. VERSAFILLER - GENERIC SETUP

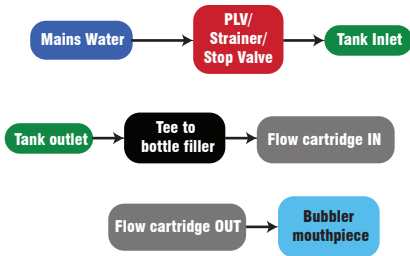

5. VERSAFILLER - SENSOR BUBBLER SETUP

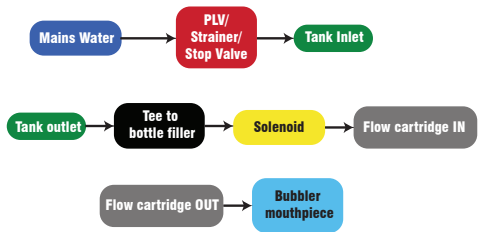

OVERLOAD PROTECTION

The compressor motor, where used, is equipped with an automatic reset protector which will disconnect the motor from the line in case of an overload.

MAINTENANCE

The only maintenance operation required is the removal of dirt and lint from the condenser of the water cooler. Inspection should be made at 3-month intervals. Disconnect the power supply cord, then clean the condenser with a small stiff non-wire brush when required. Observance of this procedure will ensure adequate air circulation through the condenser so operation is efficient and economical.

Recommended 6 monthly service

Full Inspection of unit

- Functionality of bubblers, bottle fillers drip trays, and refrigeration units checked
- Full inspection of hoses and internal fittings
- Check and adjust filter housing (if applicable)
- Adjustment of thermostat if required and operational testing performed
- Tank pressure relief valve inspected and adjusted where required.
- Incoming pressure limiting valve inspected and changed where required
- Units PCB settings checked and adjusted as required (on electronic models)

Thorough clean and sanitise unit

- Full internal and external clean of the unit performed with drink-safe cleaner
- Sell-filling systems and reservoirs are emptied and sanitised to maintain impeccable hygiene standards
- Ensured cleanliness of drip tray, outlets and exterior of unit.

Replacement of filter cartridges (filters sold separately)

- Filters are flushed and water is run through the taps to expel any carbon fines and air pockets
- Taste test and visual inspection is conducted to ensure units provide the highest quality drinking water

DISCONTINUED USE

TO DISCONTINUE USE OF WATER COOLER AND WATER FOUNTAIN

1. Close water shut off valve.
2. Provide container to catch water to be drained.
3. On push button model, disconnect power supply cord then disconnect water supply line at shut off valve. Route water supply line to container and actuate push button. If this drains too slowly for you, prepare 3/8" ID tube or 3/8" OD tube with quick-connect fitting and remove screw plug in tank drain. Slide tube over drain and route to container. Replace screw plug when draining is complete. Do not over-tighten. O-ring only needs to be snug to seal.
4. On TM and TT models, disconnect water supply line at shut off valve. Place water supply line in container and actuate solenoid as explained in Step B12. If this drains too slowly for you, disconnect power supply cord and prepare 3/8" ID tube or 3/8" OD tube with quickconnect fitting and remove screw plug in tank drain. Slide tube over drain and route to container. Replace screw plug when draining is complete. Do not over-tighten. O-ring only needs to be snug to seal.
5. ALWAYS DRAIN ALL WATER WHEN FREEZING TEMPERATURES ARE ANTICIPATED AND BEFORE SHIPPING THE WATER COOLER

TROUBLESHOOTING

| PROBLEM | POSSIBLE CAUSE | REMEDY |
|--|--|---|
| Controller is faulty | Temperature sensor is faulty | Check sensor connections. |
| | Controller display is faulty | Contact Aqua Cooler service team. |
| No water flowing out of the unit | Water source has been suspended | Restore water supply |
| | The system is clogged | Check the pipes |
| | Solenoid valve is faulty | Check controller and cable connections |
| Unit does not dispense cold water | The cooling controller is turned off | Check the position of the mechanical thermostat and set to desired temperature |
| | Power failure | Check the power cord is properly plugged in or if there is a power outage |
| | The ventilation around the unit is insufficient | Ensure sufficient ventilation space around the unit |
| | System malfunction | Contact Aqua Cooler service team. |
| | The temperature of the incoming water is too high | Ensure the unit is not placed in direct sunlight or close to other heat sources |
| Unit is noisy during operation | Chiller unit in the machine is not level | Place the chiller unit on a level flat surface. |
| | Chiller unit is touching other objects | Ensure the chiller is standing free of any surrounding objects. |
| The water being dispensed has a strange taste. | This is not uncommon with new water coolers. Do not worry, this is not dangerous to your health. | Flush as per installation instructions. Perform cleaning procedure. |

TROUBLESHOOTING

- ensure the fan is not obstructed by water pipe or otherwise before the unit is powered
- If the bottle filler is not dispensing cold water, review the internal pipework as per the above diagrams
- Pressure from the bubbler mouthpiece can be adjusted using the flow cartridge underneath the basin (this is also referred to in the manual I believe)
- (For sensor units) The sensor lens can misfire/read incorrectly when close to reflective surfaces. eg. high vis, mirror, glass.
- The built in drain is made for water only, avoid pouring viscous liquids, shakes, coffee etc. down the drain as this can cause a blockage in the drain

MARKS



WaterMark:

This product complies with the lead-free requirements of the National Construction Code Volume Three

The appliance is complying with applicable ACMA regulatory arrangements (Regulatory Compliance Mark) and Watermark WMTS 105:2016.

WARRANTY & SERVICE REGISTRATION

For All Aqua Cooler Water Cooler and Fountain Products

Effective July 2017

Aqua Cooler Pty Ltd warrants this appliance to the first purchaser as follows and subject to the stated conditions.

12 Month Comprehensive Warranty - Any defect in the appliance occurring within the first twelve months from the date of purchase will be rectified free of charge by Aqua Cooler Pty Ltd or by any authorised independent Service Agent.

24 Month Extended Warranty - Aqua Cooler Pty Ltd agrees to replace any part of the hermetically sealed refrigeration system which becomes inoperative in the two years following the first years comprehensive warranty. This extended warranty covers the compressor, condenser, and interconnecting refrigeration pipework. It excludes compressor relays, overloads and all other components of this appliance. This extended warranty does not include service, repair or labour costs or any pickup and/or freight charges. Aqua Cooler at its sole discretion may replace the cooler with a new or refurbished cooler of a similar age.

Warranty Exclusions

1. Any costs associated with the removal and reinstallation of repaired or replaced units.
2. Travel expenses to locations further than 100km from any Australian Capital City CBD or further than 100km of a registered Service Agent.
3. Damage to units where mains connected pressure is higher than 700kPa and a pressure limiting valve is not installed.
4. Where the unit is not installed as per installation instructions found within the supplied user manual.
5. The warranty does not cover defects occasioned by misuse, alterations, accident or where the water cooler has been stored on its side.

**FOR ANY CLAIMS UNDER THIS WARRANTY PLEASE CONTACT AQUA COOLER PTY LTD
PHONE: +61 (02) 9721 9300 OR EMAIL: care@aquacooler.com.au**

Thank you for your custom and we hope our product provides many years of fault free operation. To enable us to register your warranty and provide the best possible service should a problem occur, we recommend you fill out the section below and return it to us immediately.

This warranty is provided in addition to other rights and remedies you have under law: Our goods come with guarantees which cannot be excluded under the Australian Consumer Law. You are entitled to replacement or refund for a major failure and to compensation for other reasonably foreseeable loss or damage. You are also entitled to have the good repaired or replaced if the goods fail to be of acceptable quality and the failure does not amount to a major failure.

Warranty & Service Registration Form

Please fill in this form and mail to us or send via email to care@aquacooler.com.au. If this form is not completed and returned the warranty period will be deemed to have commenced from date of manufacture.

COMPANY NAME (if applicable):

CONTACT NAME:

PHONE NUMBER:

ADDRESS:

SUBURB:

POSTCODE:

MODEL NUMBER:

SERIAL NUMBER:

PURCHASED FROM:

DATE OF PURCHASE:

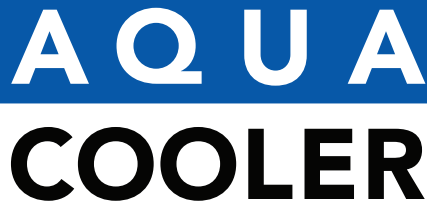

AQUA COOLER

Your Partner in Cool.

Phone Numbers

Sales: 1300 278 226
Service: 1800 278 226

Address

30-36 Relentless Court
Park Ridge QLD 4125
Australia

Internet

www.aquacooler.com.au
care@aquacooler.com.au